



**Heinzmann GmbH & Co. KG**  
**Engine & Turbine Controls**

Am Haselbach 1  
D-79677 Schönau (Schwarzwald)  
Germany

Phone +49 7673 8208-0  
Fax +49 7673 8208-188  
E-mail [info@heinzmann.com](mailto:info@heinzmann.com)  
www.heinzmann.com





V.A.T. No.: DE145551926



**HEINZMANN®**  
**Electronic Speed Governors**

# **Isochronous Load Sharing Unit**

**LMG 10-01**



 <p><b>Warning</b></p>	<p>Read this entire manual and all other publications appertaining to the work to be performed before installing, operating or servicing your equipment.</p> <p>Practice all plant and safety instructions and precautions.</p>
 <p><b>Danger</b></p>	<p>Failure to follow instructions may result in personal injury and/or damage to property.</p> <p>HEINZMANN will refuse all liability for injury or damage which results from not following instructions</p>
 <p><b>Danger! High Voltage</b></p>  <p><b>Danger</b></p>	<p><b>Please note before commissioning the installation:</b></p> <p>Before starting to install any equipment, the installation must have been switched dead!</p> <p>Be sure to use cable shieldings and power supply connections meeting the requirements of the <i>European Directive concerning EMI</i>.</p> <p>Check the functionality of the existing protection and monitoring systems.</p>
 <p><b>Danger</b></p>	<p><b>To prevent damages to the equipment and personal injuries, it is imperative that the following monitoring and protection systems have been installed:</b></p> <p>Overspeed protection acting independently of the speed governor</p> <p>Overtemperature protection</p> <p>HEINZMANN will refuse all liability for damage which results from missing or insufficiently working overspeed protection</p> <p><b>Generator installation will in addition require:</b></p> <p>Overcurrent protection</p> <p>Protection against faulty synchronization due to excessive frequency, voltage or phase differences</p> <p>Reverse power protection</p>
	<p><b>Overspeeding can be caused by:</b></p> <p>Failure of the voltage supply</p> <p>Failure of the actuator, the control unit or of any accessory device</p> <p>Sluggish and blocking linkage</p>

 <p><b>Warning</b></p>	<p><b>Electronically controlled injection (MVC) will in addition require to observe the following:</b></p> <p>With <b>Common Rail</b> systems a separate mechanical flow limiter must be provided for each injector pipe.</p> <p>With <b>Pump-Pipe-Nozzle (PPN)</b> and <b>Pump Nozzle (PNE)</b> systems fuel release may be enabled only by the movement of control piston of the solenoid valve. This is to inhibit fuel from being delivered to the injection nozzle in case of seizure of the control piston.</p>
 <p><b>Warning</b></p>	<p>The examples, data and any other information in this manual are intended exclusively as instruction aids and should not be used in any particular application without independent testing and verification by the person making the application.</p>
 <p><b>Danger</b></p>	<p>Independent testing and verification are especially important in any application in which malfunction might result in personal injury or damage to property.</p>
	<p>HEINZMANN make no warranties, express or implied, that the examples, data, or other information in this volume are free of error, that they are consistent with industry standards, or that they will meet the requirements for any particular application.</p>
	<p>HEINZMANN expressly disclaim the implied warranties of merchantability and of fitness for any particular purpose, even if HEINZMANN have been advised of a particular purpose and even if a particular purpose is indicated in the manual.</p>
	<p>HEINZMANN also disclaim all liability for direct, indirect, incidental or consequential damages that result from any use of the examples, data, or other information contained in this manual.</p>
	<p>HEINZMANN make no warranties for the conception and engineering of the technical installation as a whole. This is the responsibility of the user and of his planning staff and specialists. It is also their responsibility to verify whether the performance features of our devices will meet the intended purposes. The user is also responsible for correct commissioning of the total installation.</p>

## Contents

	Page
<b>1 Safety Instructions and Related Symbols .....</b>	<b>1</b>
1.1 Basic Safety Measures for Normal Operation.....	2
1.2 Basic Safety Measures for Servicing and Maintenance .....	2
1.3 Before Putting an Installation into Service after Maintenance and Repair Works .....	3
<b>2 Application.....</b>	<b>4</b>
<b>3 Block Diagram.....</b>	<b>5</b>
<b>4 Method of Operation.....</b>	<b>6</b>
<b>5 Technical Data.....</b>	<b>7</b>
<b>6 Wiring and Connections .....</b>	<b>8</b>
6.1 Table of Terminal Connections and their Functions .....	8
6.2 Wiring of Bus Voltages and Current Transformers .....	10
6.3 Wiring of auxiliary Contacts of Generator- and Mains Breaker .....	11
6.4 Wiring of Control Unit of Series E 1 - F and E 2 - F .....	11
6.5 Wiring of Control Unit of Series E 6 up to E 90.....	12
6.6 Wiring of Control Unit of Series E 2000.....	12
6.7 Wiring of Digital Control Unit of HELENOS Series IP 55 and IP 00.....	13
6.8 Wiring of Digital Control Unit of PRIAMOS Series .....	14
6.9 Wiring of further Load Sharing Units LMG 10-01 in Parallel Operation.....	14
6.10 Wiring of Load Setpoint Potentiometer in Parallel to Mains Operation.....	15
6.11 Wiring of Export / Import Control Unit LKG 02 with LMG 10-01.....	15
6.12 Wiring of external Load Limitation .....	16
<b>7 Measurements of Housing .....</b>	<b>17</b>
<b>8 Commissioning .....</b>	<b>18</b>
8.1 Meaning and Position of adjustment Potentiometers, LED's and Testpins .....	18
8.2 Initial Setting Up Procedure .....	20
8.3 Initial Setting of the Speed Governor.....	21
8.4 Adjustment of Synchronizer.....	21
8.5 Adjustment in Island Parallel Operation .....	22
8.6 Adjustment in Base Load Operation (Mains Parallel) .....	24
8.6.1 Setting Up the kW-Sensor in Base Load Operation: .....	24
8.6.2 Some Notes for Base Load Operating: .....	25
8.7 Adjustment of Export / Import Control with LKG 02.....	26

8.8 Adjustment of Load Limitation .....	26
8.9 Load depending Switch Point.....	27
8.10 Optional Droop Operation .....	27
8.11 Load Ramping .....	28
8.12 Substitution of the existing LMG 03 to the new LMG 10-01 .....	29
<b>9 Trouble Shooting .....</b>	<b>30</b>
9.1 Trouble Shooting in Mains Parallel Operation.....	30
9.2 Proposals for a systematic Investigation of the Failure Causes .....	30
9.3 Symptoms and possible causes.....	31
<b>10 Ordering Specifications .....</b>	<b>33</b>
<b>11 Wiring Diagrams .....</b>	<b>34</b>
<b>12 Figure List.....</b>	<b>47</b>
<b>13 Order Specifications for Manuals.....</b>	<b>48</b>

## 1 Safety Instructions and Related Symbols

This publication offers wherever necessary practical safety instructions to indicate inevitable residual risks when operating the engine. These residual risks imply dangers to

persons

product and engine

environment.

The symbols used in this publication are in the first place intended to direct your attention to the safety instructions!



Warning

*This symbol is to indicate that there may exist dangers to the engine, to the material and to the environment.*



Danger

*This symbol is to indicate that there may exist dangers to persons. (Danger to life, personal injury)*



Danger!  
High  
Voltage

*This symbol is to indicate that there exist particular danger due to electrical high tension. (Mortal danger).*



Note

*This symbol does not refer to any safety instructions but offers important notes for better understanding the functions that are being discussed. They should by all means be observed and practiced. The respective text is printed in italics.*

**The primary issue of these safety instructions is to prevent personal injuries!**

Whenever some safety instruction is preceded by a warning triangle labelled “Danger” this is to indicate that it is not possible to definitely exclude the presence of danger to persons, engine, material and/or environment.

If, however, some safety instruction is preceded by the warning triangle labelled “Caution” this will indicate that danger of life or personal injury is not involved.

**The symbols used in the text do not supersede the safety instructions. So please do not skip the respective texts but read them thoroughly!**

**In this publication the Table of Contents is preceded by diverse instructions that among other things serve to ensure safety of operation. It is absolutely imperative that these hints be read and understood before commissioning or servicing the installation.**

### **1.1 Basic Safety Measures for Normal Operation**

- The installation may be operated only by authorized persons who have been duly trained and who are fully acquainted with the operating instructions so that they are capable of working in accordance with them.
- Before turning the installation on please verify and make sure that
  - only authorized persons are present within the working range of the engine;
  - nobody will be in danger of suffering injuries by starting the engine.
- Before starting the engine always check the installation for visible damages and make sure it is not put into operation unless it is in perfect condition. On detecting any faults please inform your superior immediately!
- Before starting the engine remove any unnecessary material and/or objects from the working range of the installation/engine.
- Before starting the engine check and make sure that all safety devices are working properly!

### **1.2 Basic Safety Measures for Servicing and Maintenance**

- Before performing any maintenance or repair work make sure the working area of the engine has been closed to unauthorized persons. Put on a sign warning that maintenance or repair work is being done.
- Before performing any maintenance or repair work switch off the master switch of the power supply and secure it by a padlock! The key must be kept by the person performing the maintenance and repair works.
- Before performing any maintenance and repair work make sure that all parts of engine to be touched have cooled down to ambient temperature and are dead!
- Refasten loose connections!
- Replace at once any damaged lines and/or cables!
- Keep the cabinet always closed. Access should be permitted only to authorized persons having a key or tools.



- Never use a water hose to clean cabinets or other casings of electric equipment!

### **1.3 Before Putting an Installation into Service after Maintenance and Repair Works**

- Check on all slackened screw connections to have been tightened again!
- Make sure the control linkage has been reattached and all cables have been reconnected.
- Make sure all safety devices of the installation are in perfect order and are working properly!

## 2 Application

The HEINZMANN Load Sharing Unit LMG 10-01 will be used for isochronous load sharing between several gensets in island parallel or operating one or more gensets parallel to the mains.

In conjunction with HEINZMANN electronic speed governors the LMG 10-01 can perform the following functions:

- Load control
- Load sharing with zero speed droop
- Load limiting in parallel to the mains operation
- Reverse power alarm or load depending switchpoint (relay output)

In addition, the load sharing unit may be used in conjunction with the Load Control Unit (export / import control) LKG 02 for control of peak load and zero supply, and with the Load Switching Units LSchG 02 or LSchG 04 for switching load dependent relays.

With gas engine driven generators feeding the mains, the load sharing unit may be used to keep the output constant in spite of fluctuations in the pressure and calorific value of the gas.

When sharing the load between generators operating in parallel, the unit will control the output of each generator proportionally to its rated output. For example, a 50 kW load shared between 40 kW and 60 kW generators in parallel would be split 20 kW and 30 kW respectively.

### 3 Block Diagram

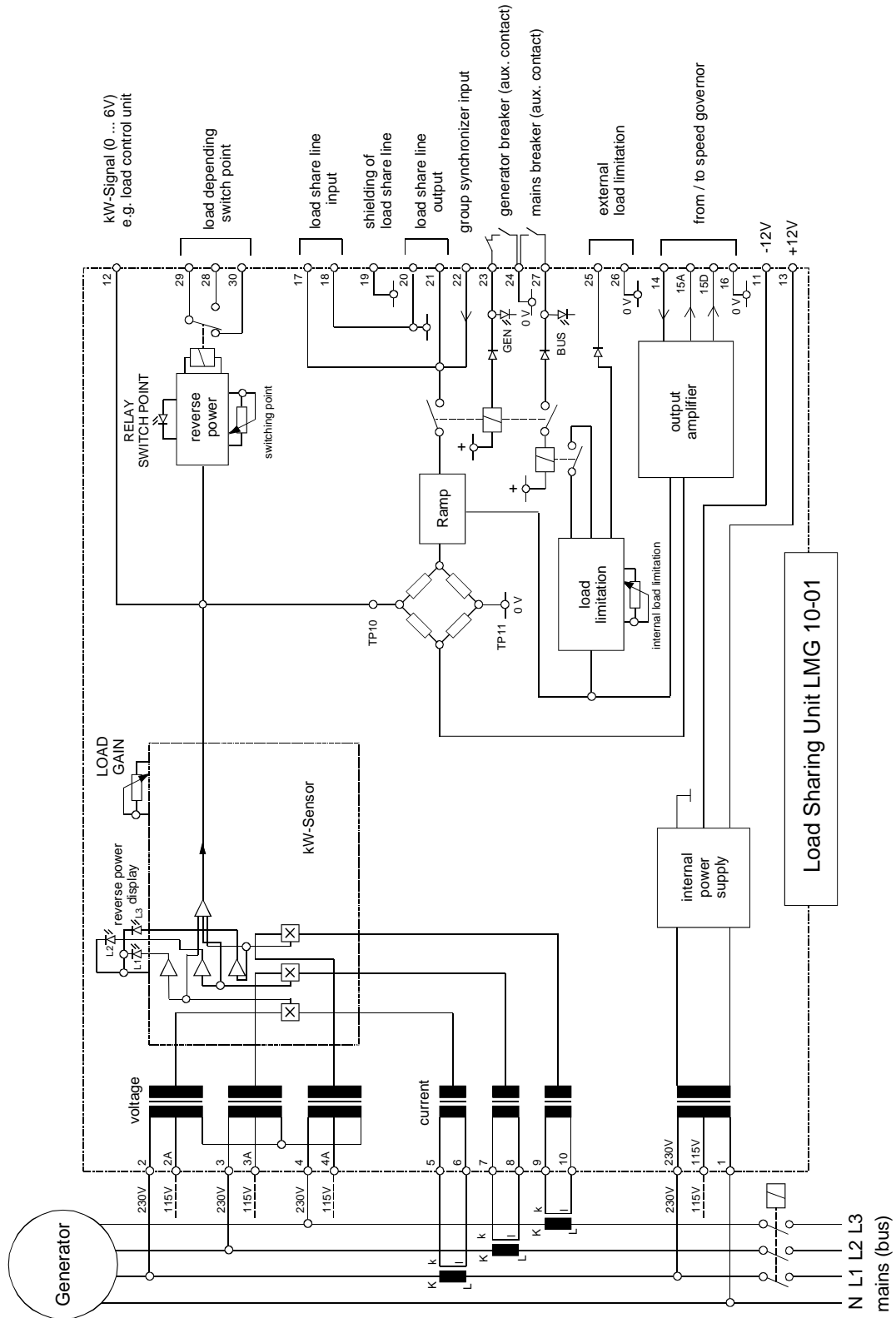

Figure 1: Block Diagram LMG 10-01

## 4 Method of Operation

The three phase voltage inputs are multiplied by the three phase current inputs and changed into a load proportional DC voltage. By this, true RMS power measuring is conducted for all three phases. The reverse power of each phase (**PHASE CURRENT**) is indicated by a red LED L1, L2, L3. If one or more LED's are on during commissioning, stop the engine and correct the wiring from the current transformers terminals k and l to the LMG 10-01 terminals. (see block diagram!).



**Danger!**  
**High**  
**Voltage**

*The plant has to be stopped before starting to work!*

The load proportional DC voltage can be measured at the internal pins TP 10 (signal) and TP 11 (0 V) and is adjustable with the potentiometer **LOAD GAIN**.

This signal is also available for external using at the terminals 12 (signal) and 16 (GND). In parallel operation with several gensets, the load share lines of the LMG 10-01 units are connected together. If the power of the paralleled generators is not equal, there originates a voltage difference on the load share lines and a small DC current will flow as long as the gensets are balanced.

## 5 Technical Data

Power supply	115/230 V AC $\pm$ 15%
<u>Signal inputs:</u>	
Voltage	3 x 115/200 V AC $\pm$ 15%
	or 3 x 230/400 V AC $\pm$ 15%
Current	0 up to 5 A per phase max. 2 VA (standard)
	or 0 up to 1 A per phase max. 2 VA (optional)
Load measuring	$U \times I \times \cos\phi$ with all three phases
Output signal	6 V DC at 100% generator power adjustable
Voltage on load share line	0 - 3 V DC
Accuracy	$\pm$ 3% at 100% generator power
Load limitation (only in mains parallel operation!)	0% up to 100% adjustable external 50% up to 100% adjustable internal
Emergency mode with droop	possible
Relay switch point	adjustable from reverse to 100% forward generator power
Contact load	max. 8 A with 250 V AC max. 0.5 A with 24 V DC
Reverse power indication	with 3 red LED's (L1 - L3)
Temperature range	-40° C up to +70° C
Protection grade	IP 44
Weight	approx. 3.8 kg

## 6 Wiring and Connections

### 6.1 Table of Terminal Connections and their Functions

Terminal	Function
115V	Supply voltage phase, with 115 V AC 50/60 Hz phase to neutral
230V	Supply voltage phase, with 230 V AC 50/60 Hz phase to neutral
1	Supply voltage neutral N
2	Voltage input phase L1, with 400 V AC 50/60 Hz phase to phase
2A	Voltage input phase L1, with 200 V AC 50/60 Hz phase to phase
3	Voltage input phase L2, with 400 V AC 50/60 Hz phase to phase
3A	Voltage input phase L2, with 200 V AC 50/60 Hz phase to phase
4	Voltage input phase L3, with 400 V AC 50/60 Hz phase to phase
4A	Voltage input phase L3, with 200 V AC 50/60 Hz phase to phase
5	Current input phase L1, terminal k of current transformer
6	Current input phase L1, terminal l of current transformer
7	Current input phase L2, terminal k of current transformer
8	Current input phase L2, terminal l of current transformer
9	Current input phase L3, terminal k of current transformer
10	Current input phase L3, terminal l of current transformer
11	-12 V DC output to connection of Load Control Unit
12	Output of load proportional voltage, + 6 V DC at 100% load, to connection of Load Control Unit
13	+12 V DC output to connection of load control unit LKG 02 or load setpoint potentiometer
14	Input LMG from connection of speed governor for actual speed setpoint
15A	Output to connection of analog speed governor for load adjustment
15D	Output to connection of digital speed governor for load adjustment
16	0 V DC output to connection of speed governor
17	Load sharing line signal input, for Load Control Unit LKG 02 or for load setpoint potentiometer
18	Load sharing line 0 V input
19	0 V for one-side connected shielding of the load sharing line cable
20	Load sharing line 0 V output

<b>Terminal</b>	<b>Function</b>
21	Load sharing line signal output
22	Load sharing line input for group synchronization
23	Connection of auxiliary contact generator breaker (closed)
24	Connection of auxiliary contact generator- and mains breaker
25	Signal input for external load limitation
26	0 V for external load limitation
27	Connection of auxiliary contact mains breaker (closed)
28	Relay contact of load switch point      NO
29	Relay contact of load switch point      Common
30	Relay contact of load switch point      NC

## 6.2 Wiring of Bus Voltages and Current Transformers

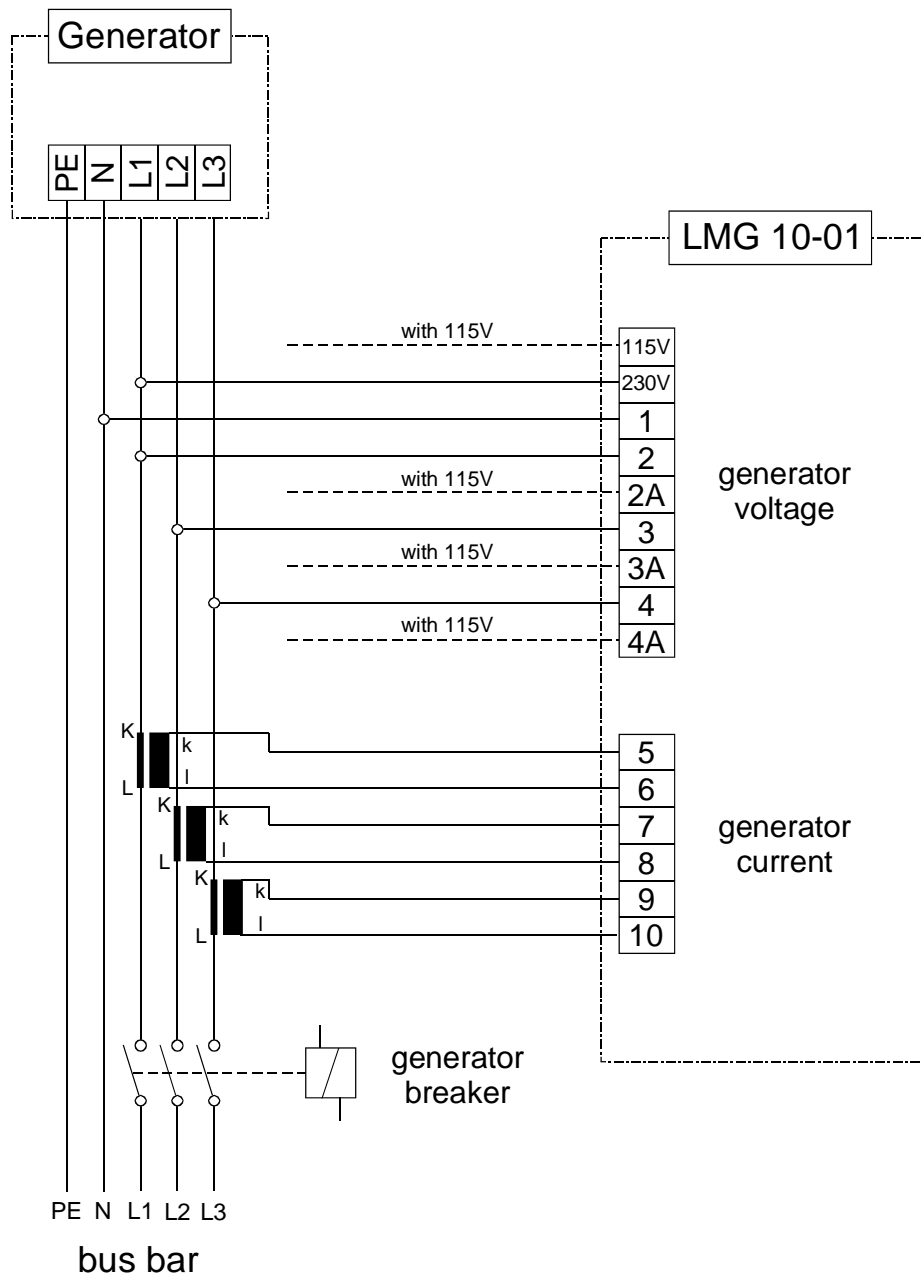

### Attention:

Take care to the right connections of the phases and the height of the voltages!

(When you have 200 V AC phase to phase, the broken lines have to be connected.)

The connections are shown in generator power control application.

Figure 2: Wiring of Bus Voltages and Current Transformers



### 6.3 Wiring of auxiliary Contacts of Generator- and Mains Breaker

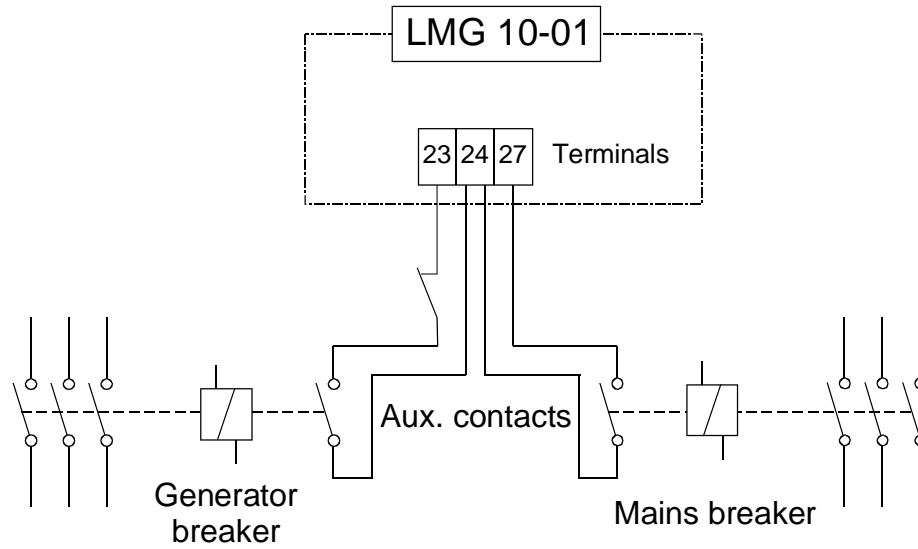

Figure 3: Wiring of auxiliary Contacts of Generator- and Mains Breaker

### 6.4 Wiring of Control Unit of Series E 1 - F and E 2 - F

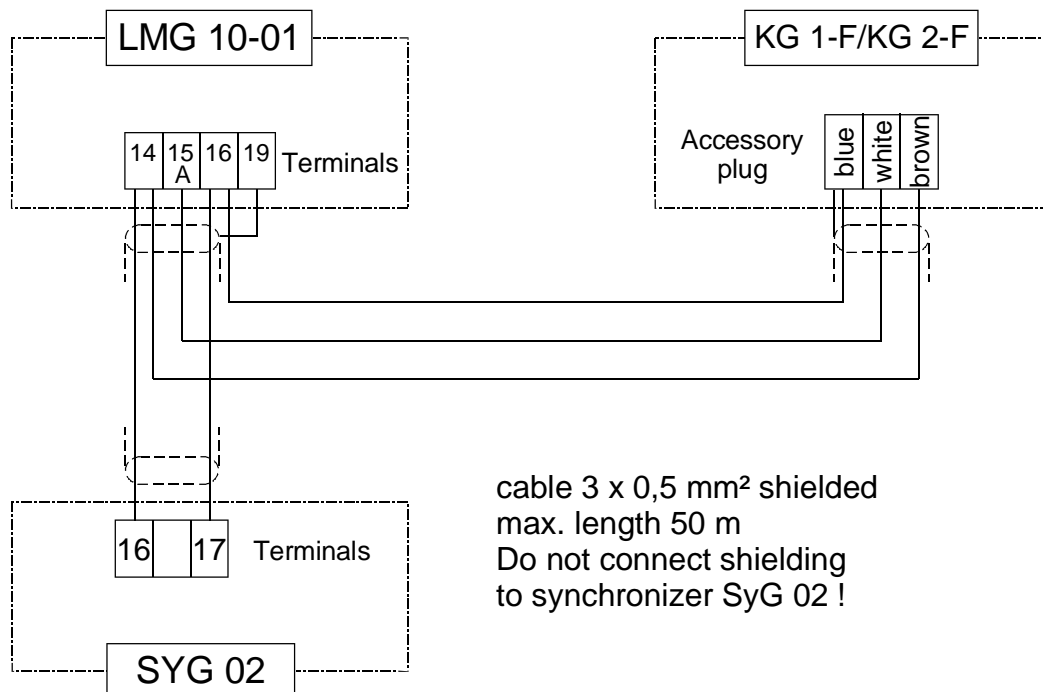

Figure 4: Wiring of Control Unit of Series E 1 - F and E 2 - F

### 6.5 Wiring of Control Unit of Series E 6 up to E 90

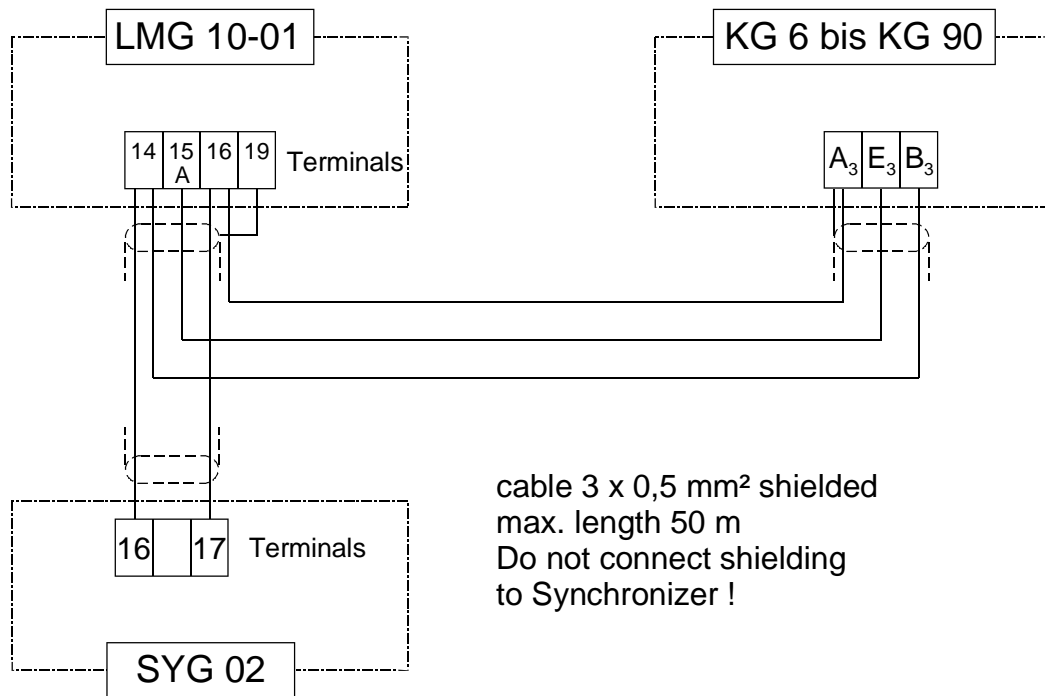

Figure 5: Wiring of Control Unit of Series E 6 up to E 90

### 6.6 Wiring of Control Unit of Series E 2000

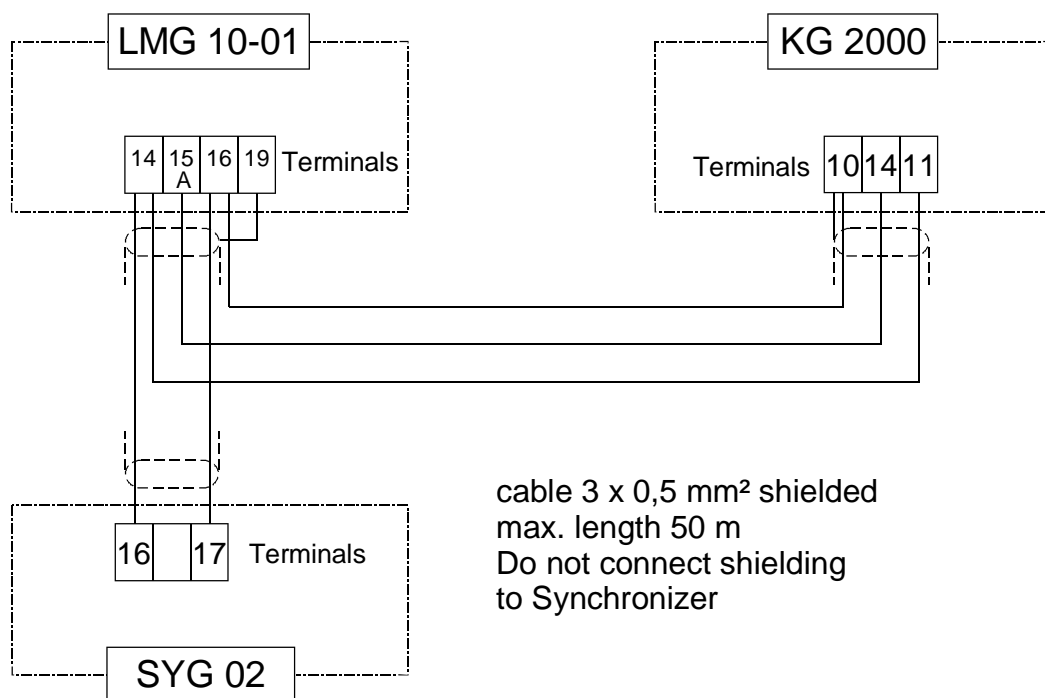
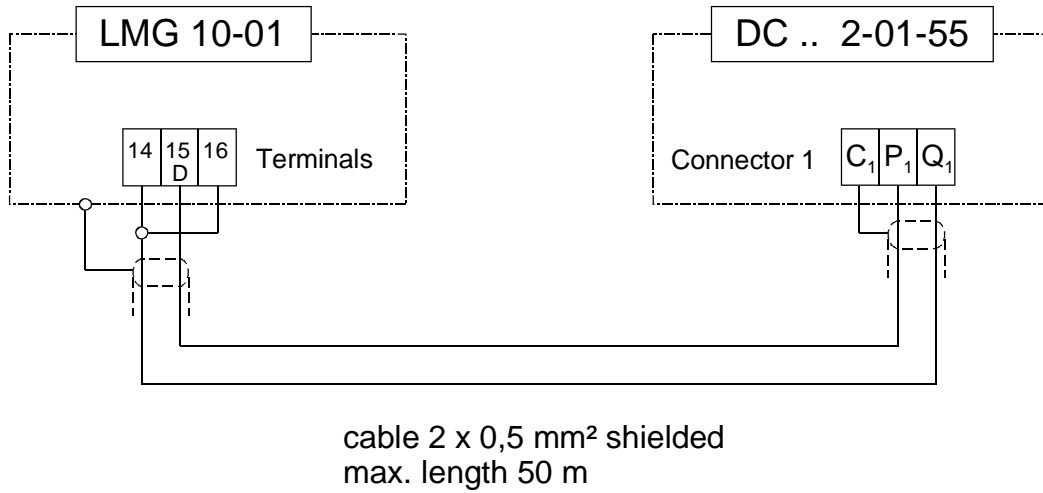
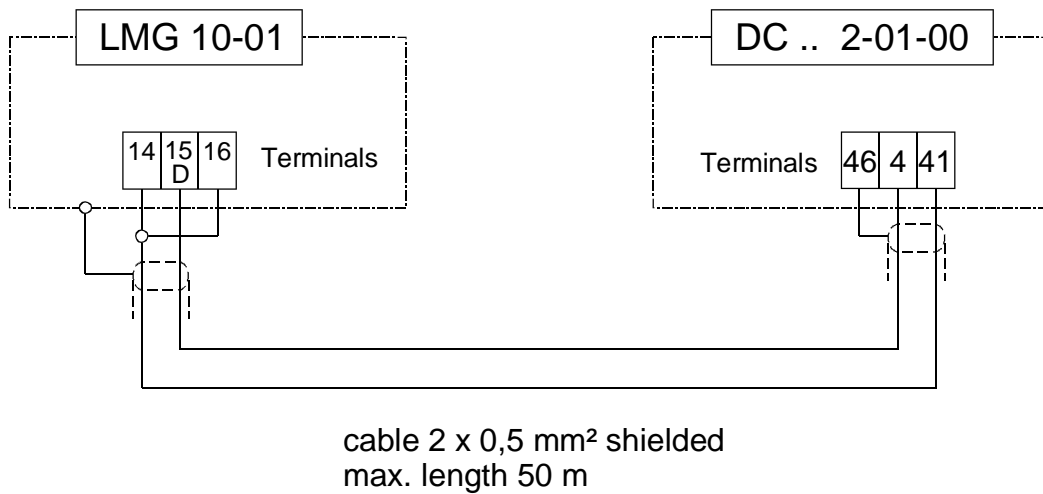

Figure 6: Wiring of Control Unit of Series E 2000

### 6.7 Wiring of Digital Control Unit of HELENOS Series IP 55 and IP 00



**Figure 7: Wiring of Digital Control Unit of HELENOS Series with Protection Grade IP 55**



**Figure 8: Wiring of Digital Control Unit of HELENOS Series with Protection Grade IP 00**

### 6.8 Wiring of Digital Control Unit of PRIAMOS Series

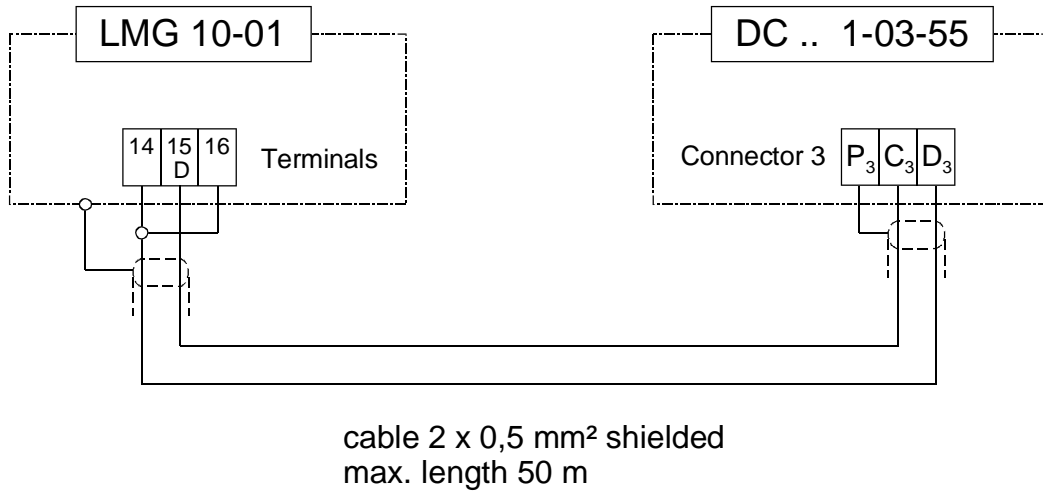
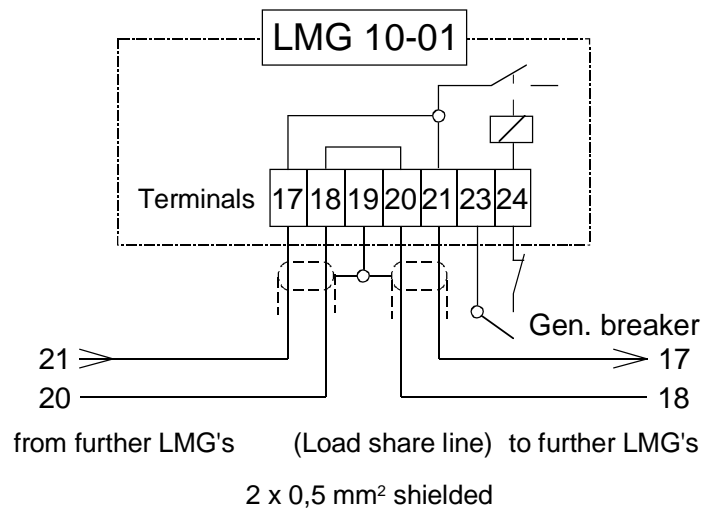

Figure 9: Wiring of Digital Control Unit of PRIAMOS Series

### 6.9 Wiring of further Load Sharing Units LMG 10-01 in Parallel Operation



The gen. breaker contact 23 & 24 activates an internal relay contact which connects the LMG with the load share lines

Figure 10: Wiring of further Load Sharing Units LMG 10-01

### 6.10 Wiring of Load Setpoint Potentiometer in Parallel to Mains Operation

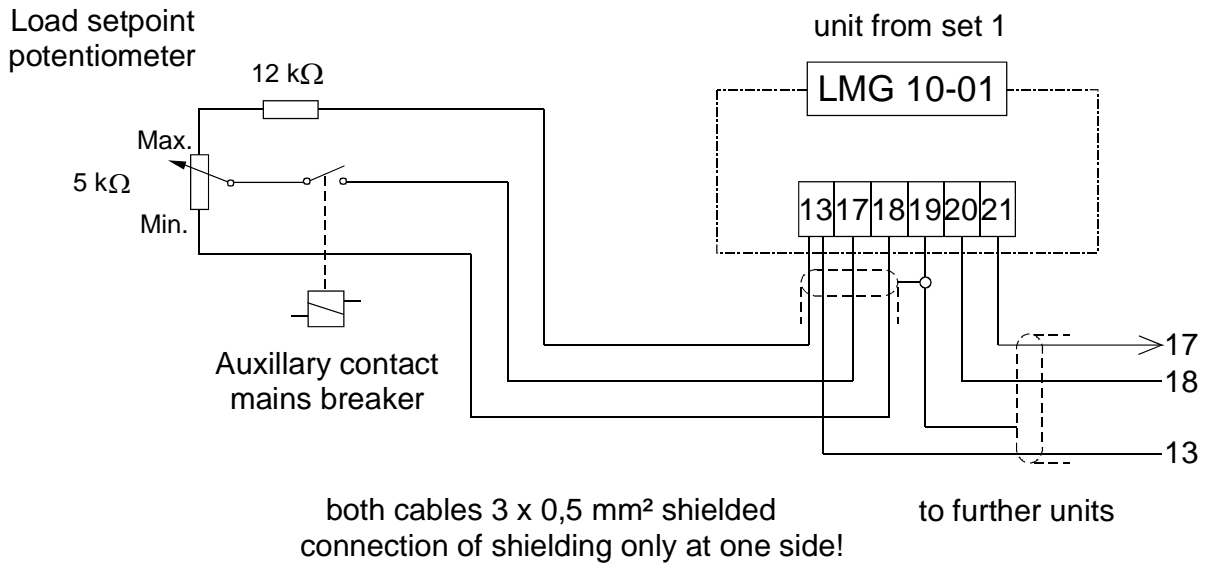

Figure 11: Wiring of Load Setpoint Potentiometer

### 6.11 Wiring of Export / Import Control Unit LKG 02 with LMG 10-01

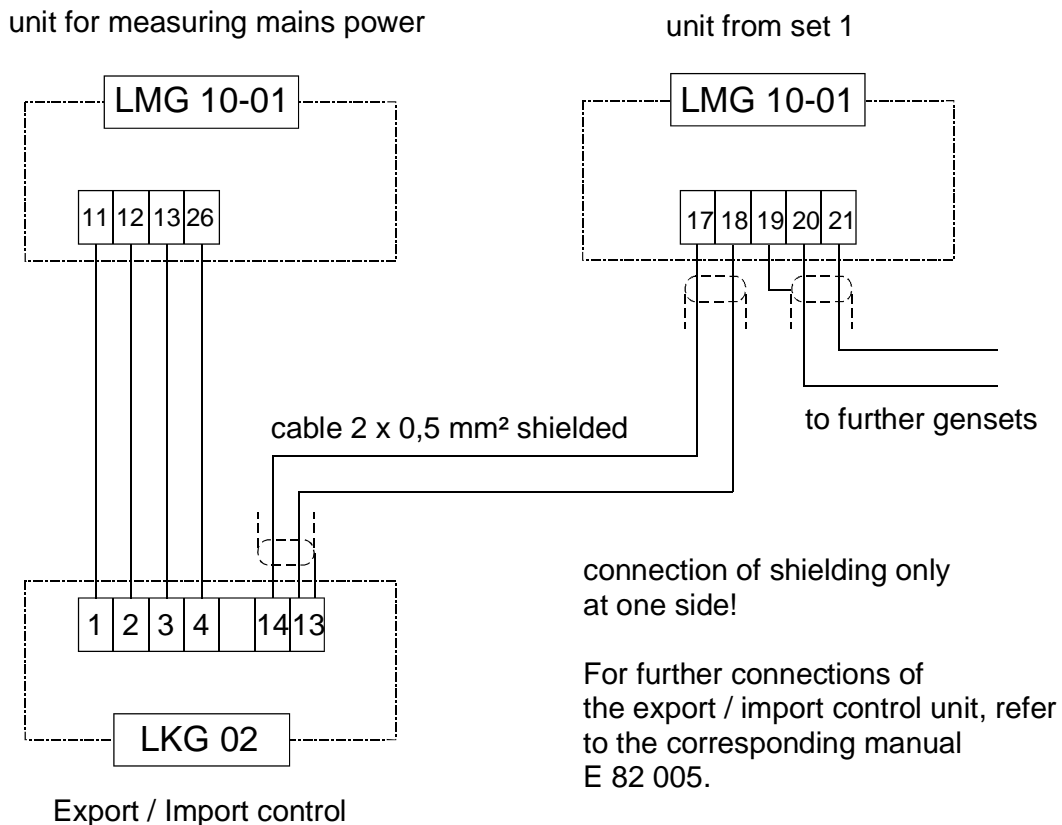

Figure 12: Wiring of Export / Import Control Unit LKG 02

### 6.12 Wiring of external Load Limitation

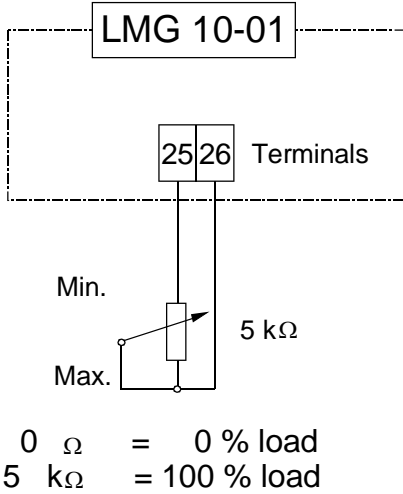
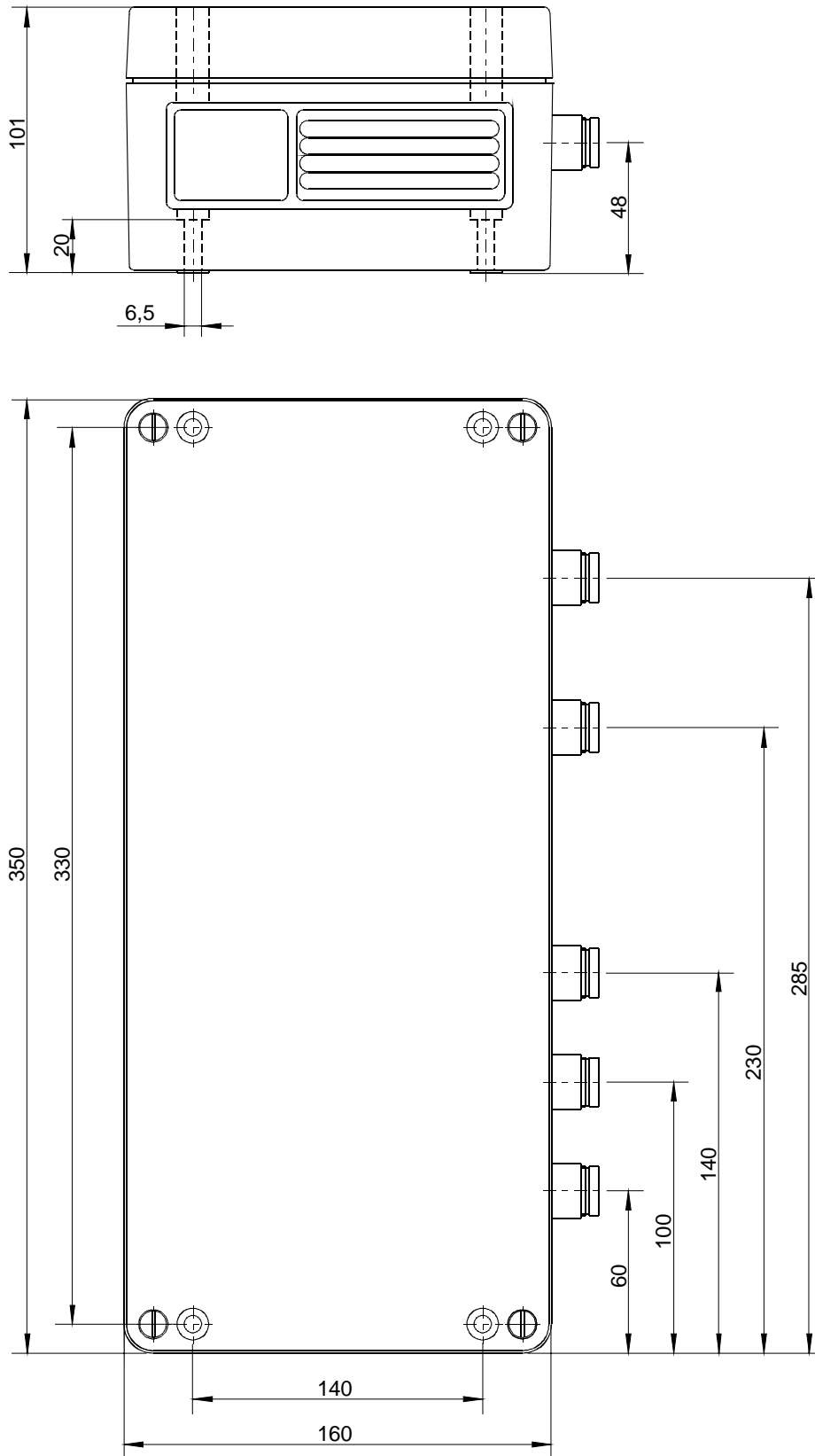

Figure 13: Wiring of external Load Limitation

## 7 Measurements of Housing



**Figure 14: Measurements of Housing**

## 8 Commissioning

### 8.1 Meaning and Position of adjustment Potentiometers, LED's and Testpins

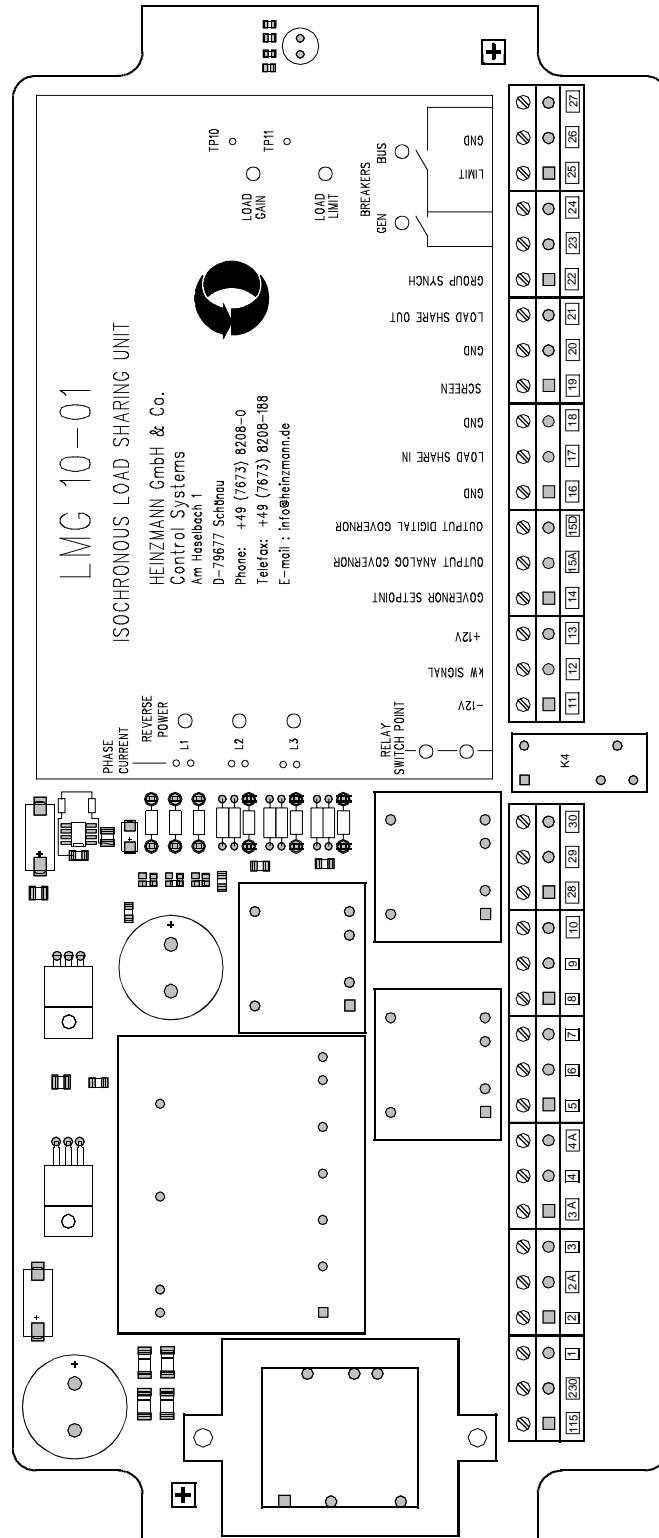

Figure 15: Position of adjustment Potentiometers, LED's and Testpins



LED	Color	Function
L1	red	REVERSE POWER on phase L1
L2	red	REVERSE POWER on phase L2
L3	red	REVERSE POWER on phase L3
	yellow	RELAY SWITCH POINT (relay energized)
	yellow	GEN. BREAKER CLOSED
	yellow	BUS BREAKER CLOSED

Potentiometer	Function
LOAD GAIN	Adjustment of load proportional DC voltage signal (for scaling of nominal load)
LOAD LIMIT	Adjustment of load limitation in parallel mains operation
SWITCH POINT	Setting of load depending relay switch point

Testpins	Function
TP10	Measuring of scaled voltage (+ 6 V DC at nominal load)
TP11	0 V measuring point for scaled voltage
2 pins for L1	CURRENT PHASE L1 (to link it out for testing)
2 pins for L2	CURRENT PHASE L2 (to link it out for testing)
2 pins for L3	CURRENT PHASE L3 (to link it out for testing)

## 8.2 Initial Setting Up Procedure



Warning

*The commissioning of a genset has to be done only by a qualified professional person !*

**8.2.1** Wire the inputs of the generator voltages and the current transformers.



Warning

*Care must be taken to the right phases and their corresponding current transformers of the high voltage connections!*

**8.2.2** Connect the 230 V AC (resp. 115 V AC) supply voltage for the load sharing unit to the generator. Connect the speed control unit to the load sharing unit and connect all load sharing units of all gensets together with load share lines.

**8.2.3** Connect the auxiliary contacts of the generator breakers and the mains breaker.

**8.2.4** Connect the synchronizer as described in the according manuals.

**8.2.5** Deactivate the synchronizer and block the closing of the generator breaker.

**8.2.6** The auxiliary contacts of the generator breaker (23, 24) and the mains breaker (24, 27) have to be open.

### 8.3 Initial Setting of the Speed Governor

For more information of initial setting of the speed governor refer to the separate corresponding manual.

- 8.3.1 Switch the droop inside the speed governor (control unit) to position zero.
- 8.3.2 Start the engine and set it to nominal speed. In doing so the generator frequency has to be adjusted as exact as possible e.g. 50 /60 Hz.
- 8.3.3 With the gain, stability and derivative potentiometers or parameters inside the speed control unit you can adjust an optimum dynamic no load behavior.

### 8.4 Adjustment of Synchronizer

- 8.4.1 Ensure that the generator breaker remains open, and activate the synchronizer device.
- 8.4.2 Adjust the settings of the synchronizer device as required by the respective manual, and optimize the parameters.



Warning

*The generator voltage has to be adjusted before synchronizing with the voltage regulator of the generator or a voltage adjusting unit. The synchronizer device can only correct the frequency and the phase angle!*



Danger!  
High  
Voltage

*Before closing the generator breaker for the first time, a stand-bysynchronization has to be conducted to check whether the voltages across the generator breaker are simultaneously approximately 0 volts for all phases. This will ensure that the assignment of the phases between the generator bus and the mains bus has been connected correctly. Take care of high voltages.*

- 8.4.3 After that, the basic adjustment of the load control unit is conducted.

## 8.5 Adjustment in Island Parallel Operation



**Danger!**  
**High**  
**Voltage**

*There must not be a voltage at the bus bar!*

- 8.5.1** Start one genset, switch it to the bus bar by hand and load the genset with an external loadbank to 20 % of the nominal load.
- 8.5.2** Connect a voltmeter with 10 V DC measuring range to the testpins TP10 and TP11 (0 V). A positive measured voltage is proportional the generator output power. If one of the REVERSE POWER LED's LED1, LED2 or LED3 is illuminated, stop the engine and correct the wiring from the current transformer to the terminals LMG 10-01. After restarting the engine the LED is extinguished and the measured voltage must increase.
- 8.5.3** Increase the generator power to 100 % and set the LOAD GAIN potentiometer, that the measured voltage at TP10 is +6 V DC. If full power is not available then the measured voltage has to be lower in accordance with the power (0 V DC equivalent 0 % power).



Note

*If +6 V at 100% load can not be reached, the following failures are possible:*

- 1) *Input voltage too low: e.g. voltage 230 V AC instead of 400 V AC phase/phase.*
- 2) *Input current too low: e.g. 2.5 A instead of 5 A at nominal load.*
- 3) *Wrong correspondence of current and voltage inputs at LMG.*

- 8.5.4** For further check of the connections short-circuit the current transformers for a short moment, for each phase in turn, on test pins PHASE CURRENT. The adjusted output voltage in 8.5.3 must decrease to 2/3 of its value (e.g. +4 V). Check the current transformer connections if this does not occur.
- 8.5.5** Adjust further gensets as described in the points 8.5.1 up to 8.5.4 and switch off all gensets at the end.

- 8.5.6** Start genset 1, switch it to the bus bar by hand and load it to 50 % of the nominal load.
- 8.5.7** The obstruction of the generator breakers at all gensets have to be removed.
- 8.5.8** Start the second preadjusted genset and synchronize it to the first one. The second genset must now take over half of the load.
- 8.5.9** Increase slowly the load to 100 %. If there is a difference of load between the units, correct it with small readjustment of potentiometer LOAD GAIN. Turning clockwise reduces the load and counterclockwise increases it.
- 8.5.10** Decrease the load to 0 %. If there is different load sharing, speed differences exist in governor speed adjustment. With readjustment of the external speed setting potentiometer of the governor of one genset you can correct this difference.
- 8.5.11** Proceed with installation 1 + 3, 1 + 4 etc. in the same way, thereby readjustments of the LOAD GAIN potentiometer and the speed setting may only be made on the new added genset.
- 8.5.12** If load hunting occurs between the generators, the output voltage value according to **8.5.3** must be reduced to +5 V or +4 V.
- 8.5.13** Now you can drive more gensets parallel together. If the adjustment described before was correct, now you have here a good load sharing also.

Remark: Differences at no load are to be corrected with the speed setting potentiometers of the speed governors and differences at full load are to be corrected with the potentiometer LOAD GAIN of the load sharing units.

## 8.6 Adjustment in Base Load Operation (Mains Parallel)

### 8.6.1 Setting Up the kW-Sensor in Base Load Operation:

#### Preliminary Remark:

During commissioning you might have the problem, there is no load bank or not enough island load available. If the diameter of the existing cable to the mains is strong enough to transfer 100% generator load into the mains you can go this way:

1. Change the isochronous speed governor into droop mode and adjust 4% droop.
2. Remove and isolate the cable from terminal 15A or 15D from LMG 10-01.
3. Connect a voltmeter with 10 V DC measuring range to the testpins TP10 and TP11 (0 V).
4. Turn the **LOAD LIMIT** potentiometer LMG 10-01 more than 20 turn fully clockwise to max.
5. Start the engine and adjust the speed back to 50/60 Hz generator frequency (the added droop changed the speed at no load to + 4%!)
6. Synchronize the genset and switch it parallel to the mains. Increase slowly the engine speed until the generator pushes 100% power into the mains.
7. Adjust in that point the potentiometer **LOAD GAIN** on your LMG 10-01 to + 6V from TP 10 to TP 11.
8. Unload the generator, open the gen.breaker and stop the engine.
9. Connect the cable in 15A or 15D and bring the speed governor back into the isochronous mode.
10. Start the engine and correct the speed to 50/60 Hz.

Now you can synchronize the genset and operate parallel to the mains.

### 8.6.2 Some Notes for Base Load Operating:

In this operation mode the load setpoint will be given via one common external potentiometer which is connected to the load share line by closing the mains breaker (fig. 11). Since all load share lines are connected together, the one potentiometer operates to all active LMGs.

You can replace the potentiometer to a voltage source (PLC), which delivers a voltage 0 to + 3V (notice, this signal should be isolated by using a DC/DC-Converter!)



Note

*If the generator is already overloaded at 3 V at TP 10, the following failures are possible:*

- 1) *Signal voltage on the three inputs too low (200V AC instead of 400V AC phase to phase)*
- 2) *Input current too low: e.g. 2.5 A instead of 5 A at nominal load, because of wrong current transformers.*
- 3) *Wrong correspondence of current and voltage inputs at LMG.*

## 8.7 Adjustment of Export / Import Control with LKG 02

With controlled mains supply one more load sharing unit LMG 10-01 has to be installed for measuring the mains power. A LKG 02 export / import control unit connected to the power signal will replace the load setting potentiometer required for base load operation. The LKG 02 will compare the set and actual values of the power to be supplied from the mains and will in its turn transmit the resulting control signal to the load sharing line.

The load sharing device is not used in the unit for measuring the mains power and is not needed to be connected as well as the auxiliary contacts of the breakers. The connection of the load control unit LKG 02 to the load measuring unit is shown in fig. 12.

The adjustment of the generator load sharing units has to be as described in chapter 8.6. When all adjustments are correct, the external load setting potentiometer will be switched over to the connection of the load control unit LKG 02. The potentiometer LOAD GAIN of the load measuring unit to measure the mains power has to be turned fully clockwise to max.. More adjustments are not necessary at this unit. For further information of the adjustment of the load control unit refer the corresponding manual No. E 82 005.

## 8.8 Adjustment of Load Limitation

To protect the generator against overloading when operating in parallel to the mains, the maximum load may be limited by using an internal or external potentiometer. With this facility it is possible to limit the load regardless of gas pressure or calorific value in the case of gas engines. Thus, the set load will not be exceeded even if the actual power setpoint has been set to some higher value.

The load limitation can be used in mains operation **only!**

- 8.8.1** Start the genset and parallel to the mains.
- 8.8.2** Set with the load setpoint potentiometer approx. 110 % of nominal load.
- 8.8.3** If you like using an internal load limiter, turn the potentiometer LOAD LIMIT beginning from the maximum counterclockwise until you reach the demanded maximum load.
- 8.8.4** If you want to connect an external load limiter, turn at first the internal potentiometer LOAD LIMIT fully clockwise to maximum. Then slowly turn the



external connected load limitation potentiometer as shown in fig. 13, page 13 counterclockwise until you reach the demanded maximum load.

- 8.8.5** Check the adjustment by turning the load setting potentiometer counterclockwise and clockwise.

You can replace the external load limitation potentiometer by a voltage source 0V up to +3V DC. This will allow you a load limitation by means of a CHP (Attention to potential separation!).

### **8.9 Load depending Switch Point**

The switch point potentiometer allows you to adjust a load depending relay output. The range of adjustment operates from reverse to 100 % forward power. The switch point is indicated by a yellow LED if the relay is energized.

### **8.10 Optional Droop Operation**

If a load sharing with droop is necessary, the load share lines and the auxiliary contacts of the generator breakers mustn't to be connected (terminals 17/18, 20/21 and 23/24).

Connect an additional potentiometer 5 k $\Omega$  from terminal 17 to 18 (as shown in fig. 16)

Adjust the potentiometer to 4 % droop (difference from no load to max. load).

Turning the potentiometer in CCW direction will increase the droop and vice versa.



Note

*If there are more than one genset in droop mode, make sure that all units are adjusted to the same droop level.*



## 8.12 Substitution of the existing LMG 03 to the new LMG 10-01

<b>LMG 03 (old)</b>	<b>LMG 10-01 (new)</b>
Terminal 15 = signal output to the Heinzmann speed governor	15A to the Heinzmann Analog speed governor 15D to the Heinzmann Digital speed governor
External resistor for load setpoint potentiometer 15kΩ	External resistor for load setpoint potentiometer 12 kΩ
No soft loading	Soft load ramp integrated, additional contact (23 & 24) in series necessary
No indication breakers closed	LED indications breakers closed
Droop potentiometer intern	Optional droop potentiometer extern
Relais reverse power	Adjustable trippoint for forward- and reverse power

## 9 Trouble Shooting

### 9.1 Trouble Shooting in Mains Parallel Operation

#### **Important:**

In the event of a failure, refrain from instantaneously changing the settings of the load measuring unit, of the synchronizer, or of the control unit of the governor.

Often, the fault is not likely to be caused by the control system.

Particularly with gas engines, irregularities of the engine (e.g. ignition system, spark plugs, etc.) will also have an effect on load sharing in general and, due to the paralleled load measuring units LMG 10-01, on the load sharing of other engines resp. gensets that are on the whole working correctly.

Also bad var sharing from the generators can give unstability in the loadsharing.

### 9.2 Proposals for a systematic Investigation of the Failure Causes

Proceed by the following sequence of steps:

#### 9.2.1 Actuator of the electronic speed governor

Check whether the external positioning lever of the actuator is at the 100% position and is not able to open any further. If the lever is at this position look at your engine!

*Possible Causes:* e.g. variations of gas quality, particularly of sewage gas  
spark plugs defective  
ignition system at fault

9.2.2 Check engine speed on zero load and correct adjustment if necessary - to do so see item 8.3.3.

9.2.3 Check load sharing at minimum and maximum generator load and conduct readjustment if necessary.

9.2.4 Check load limitation and readjust if necessary - to do so see item 7.8.

### 9.3 Symptoms and possible causes

Symptom	Possible Cause
<p>Generator set does not share load with others or trips on reverse power</p>	<p>wrong connection on load sharing lines terminals 17 up to 21</p> <p>wrong LOAD GAIN adjustment refer point 8.5.9 or 8.6.9.</p> <p>wrong connection of current transformer or voltage input</p> <p>refer point 8.5.4 or 7.6.8.</p> <p>incorrectly adjusted engine speed at no load condition</p> <p>because of wrong wiring load limitation is on while island operation active</p> <p>no AC power to unit or one phase is missing</p>
<p>Generator set speed drops when loaded</p>	<p>actuator at maximum position</p> <p>auxiliary contact of generator breaker is not closed or wrong connected</p> <p>short circuit in load share lines</p> <p>speed governor is set to droop mode</p>
<p>Load sharing not correct</p>	<p>maximum load sharing not correct, check LOAD GAIN setting of LMG 10-01</p> <p>minimum load sharing not correct, check governor speed for no load operation</p>

<b>Symptom</b>	<b>Possible Cause</b>
<p>Generator set does not takes load when in parallel with the mains</p>	<p>refer to: generator set does not share load with others</p> <p>external load limitation setting at zero</p> <p>check actuator position for free movement</p> <p>check voltage between            terminals 16 - 11 -12 V DC            terminals 16 - 13 +12 V DC            terminal 16 is 0 V</p>
<p>Generator set is overloaded when in parallel with the mains</p>	<p>refer to: generator set does not share load with others</p> <p>gain setting on load measuring unit too low</p> <p>check voltage between            terminals 16 - 11 -12 V DC            terminals 16 - 13 +12 V DC            terminal 16 is 0 V</p>

## 10 Ordering Specifications

Please order:                      LMG 10-01

Following information is necessary for ordering:

Generator voltage	115/200 V AC or 230/400 V AC (phase to phase)
Current transformer	1 A or 5 A at nominal load (5 A is standard, 1 A is optional)
Governor type	analog governor or digital governor when digital governor, exact type (HELENOS, PRIAMOS, ARTEMIS, DARDANOS, PANDAROS)

without user specifications the LMG 10-01 will be delivered as follows:

Generator voltage	230/400 V AC 50/60 Hz (phase to phase)
Current transformers	5 A at nominal load

## **11 Wiring Diagrams**

The following pages are showing examples of wiring diagrams for different generator applications with the necessary HEINZMANN components.











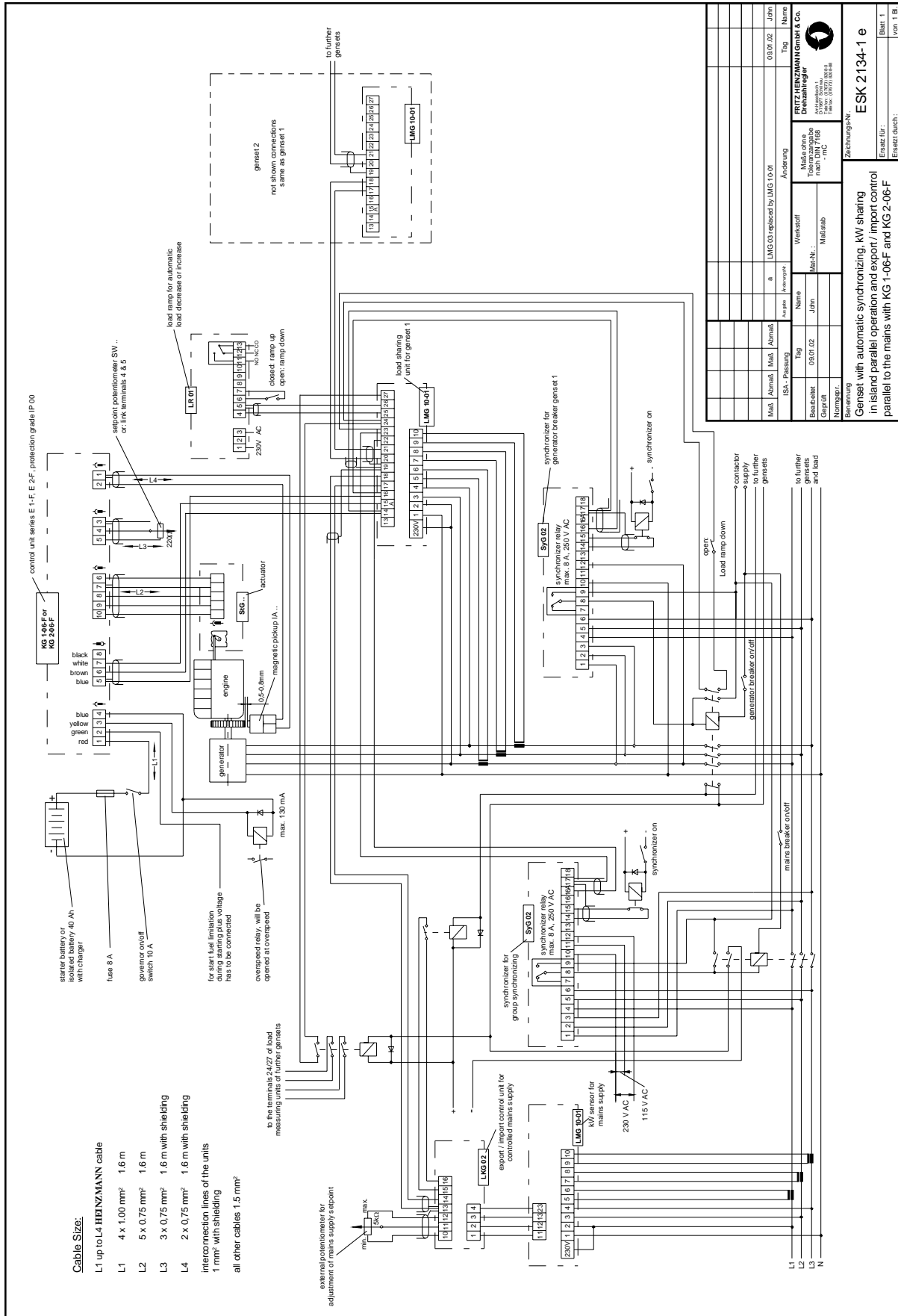

Figure 22: Automatic Synchronizing in Export / Import Control with KG 1/2-06-F









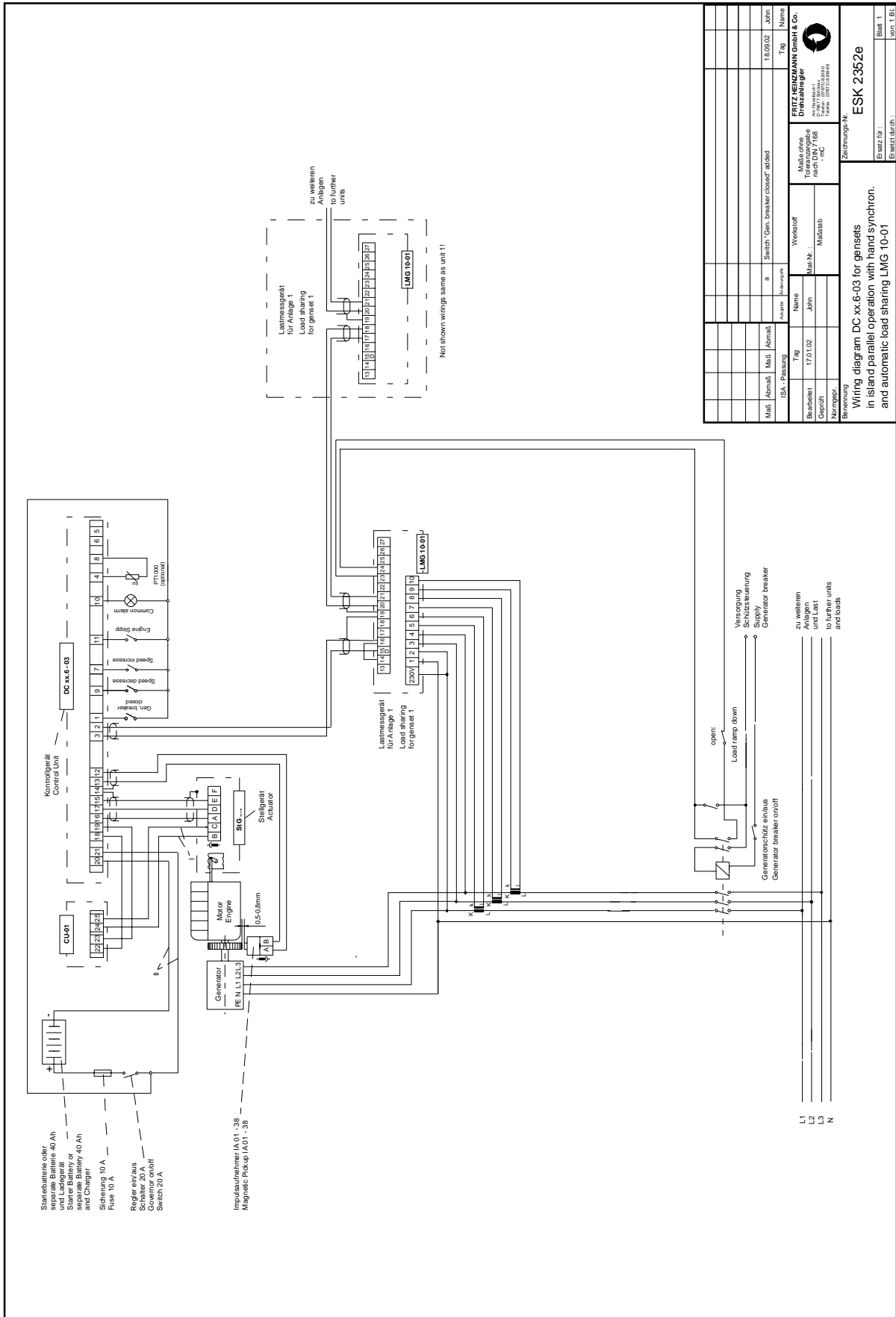

ESK-Prüfung	Name	Abmaß	18.08.02	John
Maß / Normmaß	Maß / Normmaß	Maß / Normmaß	Maß / Normmaß	Maß / Normmaß
Benennung	Benennung	Benennung	Benennung	Benennung
Zeichnungs-Nr.	ESK 2352e			
Erstellt durch	von 1 BL			

Wiring diagram DC xx.2-01 for gensets in island parallel operation with hand synchron. and automatic load sharing LMG 10-01

Figure 26: Manual Synchronizing in Island Parallel Operation with DC xx.2-01-00







## 12 Figure List

Figure 1: Block Diagram LMG 10-01.....	5
Figure 2: Wiring of Bus Voltages and Current Transformers.....	10
Figure 3: Wiring of auxiliary Contacts of Generator- and Mains Breaker .....	11
Figure 4: Wiring of Control Unit of Series E 1 - F and E 2 - F .....	11
Figure 5: Wiring of Control Unit of Series E 6 up to E 90 .....	12
Figure 6: Wiring of Control Unit of Series E 2000.....	12
Figure 7: Wiring of Digital Control Unit of HELENOS Series with Protection Grade IP 55. 13	
Figure 8: Wiring of Digital Control Unit of HELENOS Series with Protection Grade IP 00. 13	
Figure 9: Wiring of Digital Control Unit of PRIAMOS Series .....	14
Figure 10: Wiring of further Load Sharing Units LMG 10-01 .....	14
Figure 11: Wiring of Load Setpoint Potentiometer.....	15
Figure 12: Wiring of Export / Import Control Unit LKG 02 .....	15
Figure 13: Wiring of external Load Limitation.....	16
Figure 14: Measurements of Housing .....	17
Figure 15: Position of adjustment Potentiometers, LED's and Testpins .....	18
Figure 16: Optional Droop Operation .....	28
Figure 17: Load Ramp.....	28
Figure 18: Auto. Synchronizing in Island Parallel and Base Load Operation with KG 2000. 35	
Figure 19: Auto. Synchronizing in Island Parallel and Base Load Op. with KG 1/2-06-F ..... 36	
Figure 20: Auto. Synchronizing in Island Parallel and Base Load Op. with KG 6 to KG 40 . 37	
Figure 21: Automatic Synchronizing in Export / Import Control with KG 2000..... 38	
Figure 22: Automatic Synchronizing in Export / Import Control with KG 1/2-06-F..... 39	
Figure 23: Automatic Synchronizing in Export / Import Control with KG 6 to KG 40..... 40	
Figure 24: Auto. Synchronizing in Island Parallel and Base Load Op. with DC xx.2-01-00.. 41	
Figure 25: Auto. Synchronizing in Island Parallel and Base Load Op. with DC xx.6-04-00.. 42	
Figure 26: Manual Synchronizing in Island Parallel Operation with DC xx.2-01-00..... 43	
Figure 27: Manual Synchronizing in Mains Parallel Operation with DC xx.6-03-00..... 44	
Figure 28: Automatic Synchronizing in Island Parallel Operation with DC xx.6-04-00..... 45	
Figure 29: Automatic Synchronizing in Island Parallel Operation with DC xx.2-01-00..... 46	

## 13 Order Specifications for Manuals

There is no charge for our technical manuals ordered in reasonable quantities.

Order the necessary manuals on our speed governors from your nearest

[HEINZMANN location](#).

(Please click on “HEINZMANN location” to see the list of our subsidiaries and agents in the world).

### **Please include the following information:**

- your name,
- the name and address of your company (you can simply include your business card),
- the address where you want the manuals sent (if different from above),
- the number(s) (as on front page bottom right) and title(s) of the desired manual(s),
- or the technical data of your **HEINZMANN** equipment,
- the quantity you want.

You can directly use the following fax-form for ordering one or several manuals.

Most of the manuals are available as acrobat PDF-files, too. On request they can be send via e-mail.

We solicit comments about the content and the presentation of our publications. Please, send your comments to:

### **HEINZMANN GmbH & Co. KG**

Service Abteilung

Am Haselbach 1

D-79677 Schönau

Germany

# Fax Reply

## Order for HEINZMANN technical manuals

**Fax-Hotline +49 7673 8208 194**

Please send me the following manuals:

Quantity	No. of the manual	Title

Please send me your new sales documentation about

( ) the HEINZMANN Analogue Governors      Application:.....

( ) the HEINZMANN Digital Governors      Application:.....

( ) the HEINZMANN Gas Engine Equipment      Application:.....

Company .....

Contact Person.....

Department .....

Address..... Country/Code/Town.....

Phone..... Fax .....

E-Mail.....

Activity.....

Date .....